

MIZU

BLOC VANITY UNIT WALNUT



To see the complete Mizu range go to
www.reece.com.au/bathrooms

SPECIFICATIONS

Recommended use	Domestic
Available Sizes	900 x 470 x 279mm 1200 x 470x 279mm 1500 x 470 x 279mm
Colour	Satin White/Walnut
Drawer material	Satin White MDF
Cabinet Material	Walnut
Configuration	Left Hand Drawer Only
Fixing:	Screwed to wall with screws and hanging clips (included)
Weight:	900mm: 23kg (cabinet only) 1200mm: 27.5kg (cabinet only) 1500mm: 33.5kg (cabinet only)
Basin Cut Out	Pre cut 130mm x 235mm generic cutout for basin waste and tapware connections
Drawer mechanism	Soft Closing

CLEANING RECOMMENDATIONS

We recommend the use of soapy water or approved cleaners.

This product should not be cleaned with abrasive materials.

Damage caused by any improper treatment is not covered by the product warranty- refer to Warranty Conditions.

Disclaimer: Products in this specification manual must by regulation be installed by licensed and registered trade people. The manufacturer/distributor reserves the right to vary specifications or delete models from their range without prior notification. Dimensions are nominal measurements only. Dimensions and set-outs listed are correct at time of publication however the manufacturer distributor takes no responsibility for printing errors.

Tech Page Version 2

MIZU

BLOC VANITY UNIT

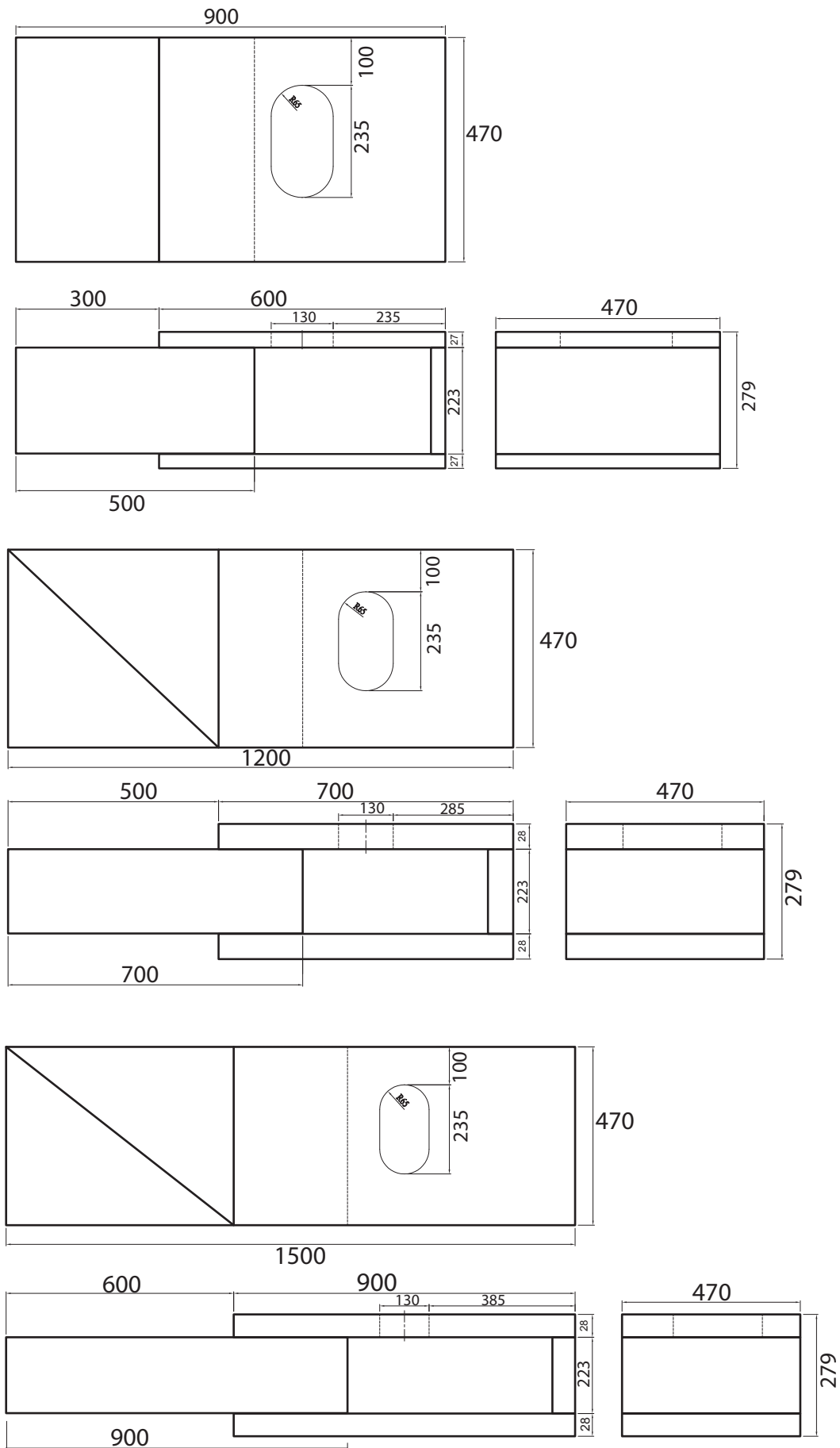

MIZU

BLOC VANITY UNIT

Dimensions are nominal measurements only.

INSTALLATION INSTRUCTIONS

Note:

Vanity unit must be installed by a qualified tradesman.

Important

If fixing to timber framed walls or partitioning, care should be taken to properly reinforce wall.

Please check vanity unit for damage before installing. If there is damage please notify Reece branch where the product was purchased to organise a replacement product. Installation of the vanity unit is deemed as accepting the condition of the vanity unit.

Installation Procedure

1. Ensure that wall is plumb.
2. Set up water inlet point and waste.
3. Mark out the position of the screws and pre-drill wall. These are to line up with pre drillings inside drawer of the unit.
4. Install hanging brackets with screws supplied. These are to line up with hanging clips installed in cavity section of unit.
5. Place vanity unit into position and partially secure to wall. Make minor adjustments to hanging clips and then fully tighten screws.
6. External edges where the unit meets the wall should be sealed using flexible sealant.

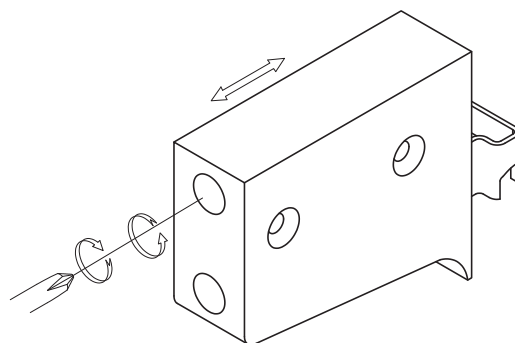
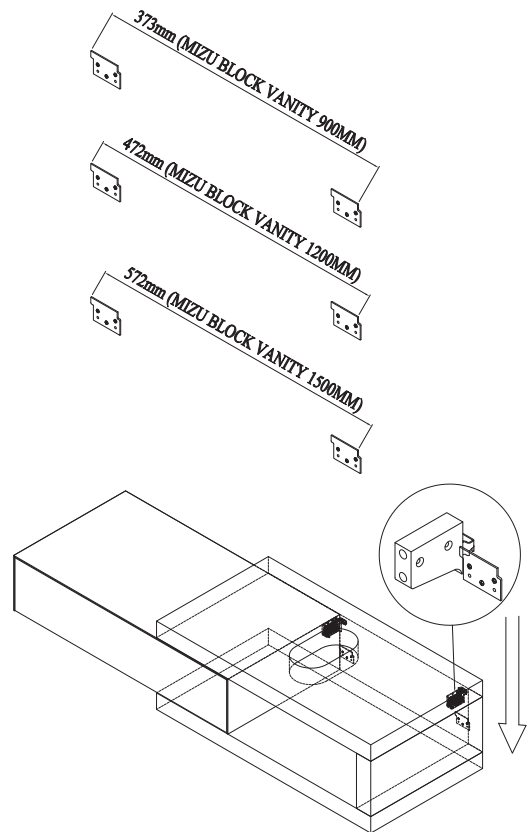
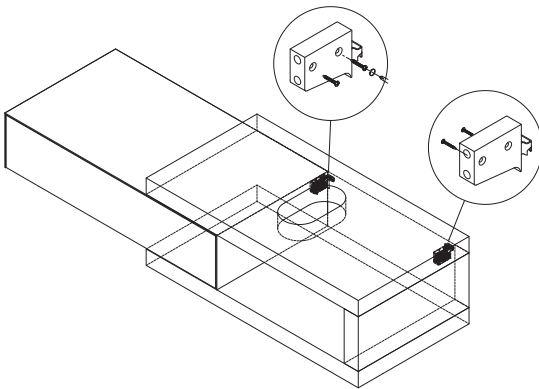
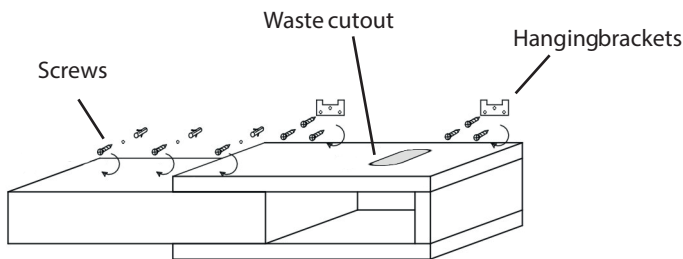

Plumbers, please ensure a copy of the installation instructions is left with the end user for future reference

MIZU

BLOC VANITY UNIT

HOW TO REMOVE SLIDING DRAWER

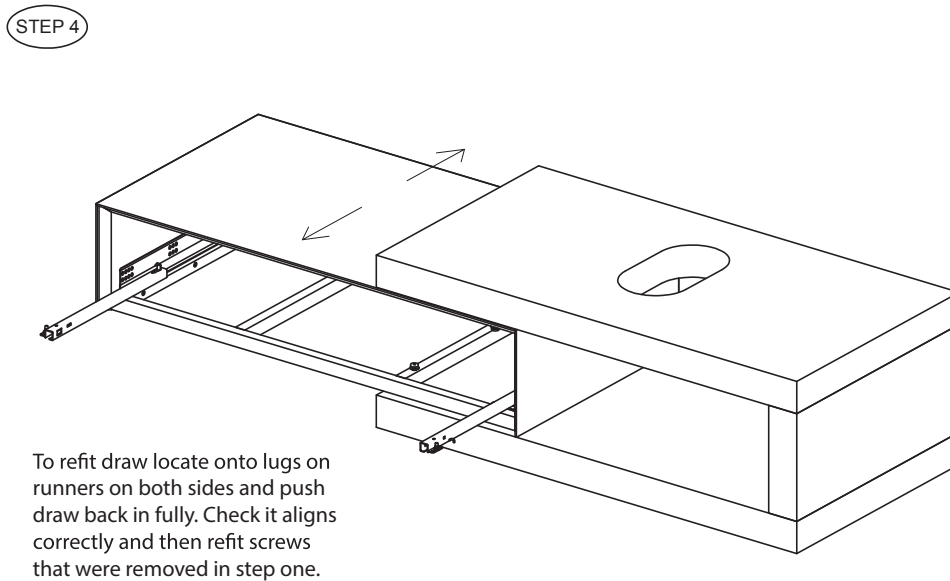
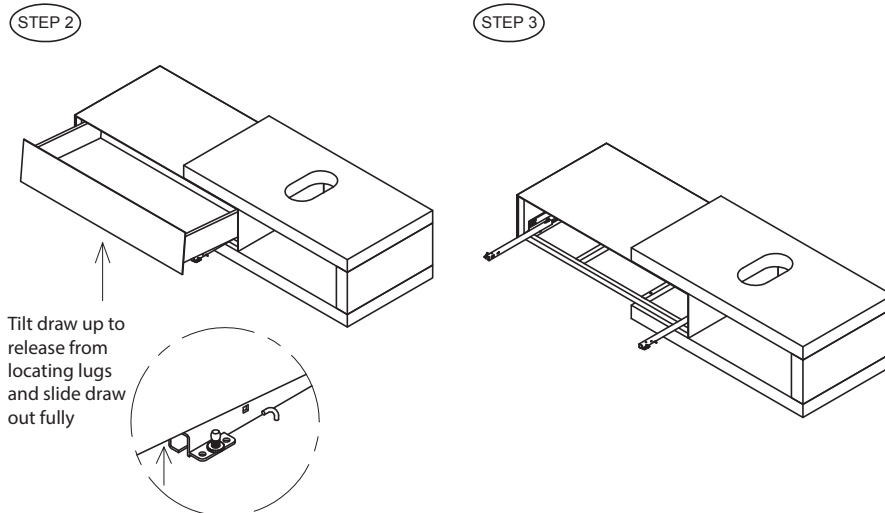
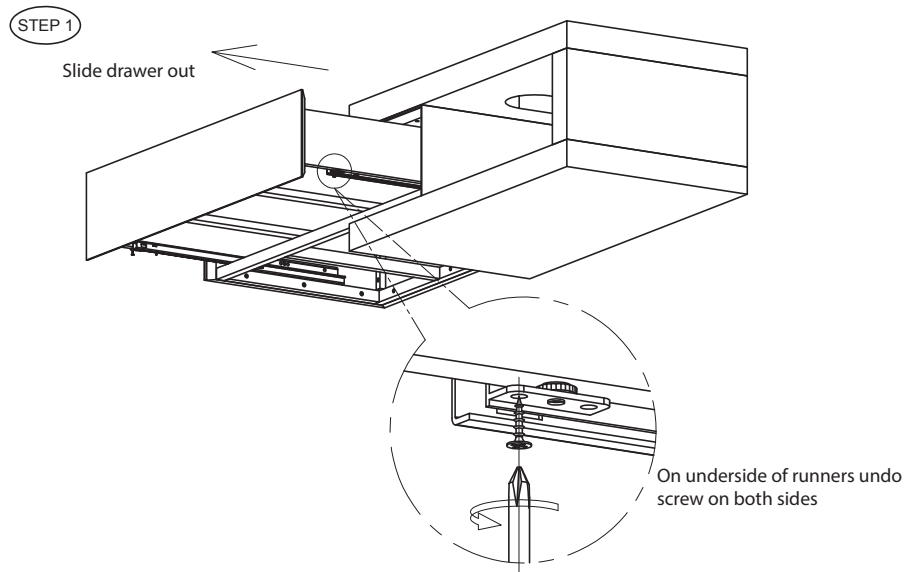

MIZU

BLOC VANITY UNIT



REECE PRODUCT QUALITY GUARANTEE

You have purchased a quality product from Reece Pty Ltd ABN 84 004 097 090 ("Reece"). This product is covered by a 7 year replacement product warranty and a 12 month warranty over spare parts and labour.

7 YEAR WARRANTY – DOMESTIC USE

This warranty covers faults in the product construction, material and assembly. Products which are within 7 years from the date of purchase, found upon inspection by an authorised Reece representative, to be defective in construction, material or assembly, will be repaired or exchanged with an equivalent product free of charge. Replaced items become Reece's property.

All replacement products will be available for collection without charge to the customer at the nearest Reece branch to the customer's location, or elsewhere as agreed between the customer and Reece.

Labour and Spare Parts

The labour for the replacement of products and spare parts to which this warranty applies will be supplied by Reece or relevant supplier using licensed plumbers engaged by Reece or relevant supplier within 1 year from the date of purchase.

Spare parts which are within 1 year from the date of purchase found upon inspection by an authorised Reece representative to be defective in construction, material or assembly, will be replaced free of charge.

Warranty Conditions

This warranty will apply only under all of the following conditions:

- The item has been installed by a licensed plumber
- The item has been installed for and subjected to domestic residential use only
- Failure is due to a fault in the manufacture of the product
- Proof of purchase (including the date of purchase) is provided
- The installation of the product is in accordance with the instructions provided

This warranty does not include faults caused by:

- Unsuitable or improper use
- Incorrect installation or installation not in accordance with the instructions provided
- Installation or part installation by the purchaser or any person other than a LICENSED PLUMBER
- Normal wear and tear
- Inadequate or complete lack of maintenance
- Chemical, electrochemical or electrical influences
- Harsh detergents or abrasive cleaners used on product finishes

1 YEAR WARRANTY – COMMERCIAL USE

'Commercial' use is all use other than for normal domestic residential purposes, including use in non-business places as in public buildings, schools, sports centres and in establishments that contain private bathrooms with high frequency of use by many individuals, such as hotels, motels, retirement villages and hospitals.

The Commercial warranty covers this product against manufacturing faults in the construction, material and assembly of both the finished products and any spare parts for a period of 1 year from the date of purchase. Products and spare parts which are found upon inspection by an authorised Reece representative to be defective in construction, material or assembly will be repaired or exchanged free of charge. Replaced items become Reece's property. The labour for the replacement of products and spare parts to which this warranty applies will be supplied by Reece or relevant supplier using licensed plumbers engaged by Reece or relevant supplier. The Warranty Conditions and exclusions which apply to the domestic use warranty also apply to this commercial warranty.

EXCLUSIONS

To the fullest extent permitted by law, Reece excludes all liability for damage or injury to any person, damage to any property, and any indirect consequential or other loss or damage.

CLAIM PROCEDURE

For all warranty queries customers are to contact the branch where the product was purchased. These details can be found on your purchase invoice.

Our goods come with guarantees that cannot be excluded under the Australian Consumer Law. You are entitled to a replacement or refund for a major failure and for compensation for any other reasonably foreseeable loss or damage. You are also entitled to have the goods repaired or replaced if the goods fail to be of acceptable quality and the failure does not amount to a major failure.